

Model 3540 LI

20 A max out • 198-264 VAC input

- 3-step charge control with current detection
- Input voltage 198-264 VAC. 115 VAC versions available.
- Fixed mains cable, 2-pin IEC 60320 available
- Output terminal: cord w. open ends, XLR output plug for wheelchairs and scooters available
- Wake up and low current start-up of deeply discharged batteries
- Safety indication and protection: against reverse polarity, short circuit, charging battery packs with the wrong number of cells and safety timer run-out
- Approvals:
 - Medically certified
 - Safety: EN 60601-1 ed. 3.1
 - Home healthcare EN 60601-1-11 (fixed cord vers. only)
 - EMC: EN 60601-1-2 ed. 4
 - UL approved
- Custom specifications on request:

Charging parameters, connectors, cords, logo print, housing/open frame/IP rating and certificates. For more information: [custom design info sheet](#)

Notes:

Desktop unit

Mounting bracket included

With NTC input on request

2MOOP standard, 2MOPP available (3540P)

Std. DC output cord:

Open ends, L 1.1m, AWG 13, Black PVC, UL 1185

Blueline



Available versions On request

2 cell / 20A

3 cell / 20A

4 cell / 17,5A

6 cell / 10A

7 cell / 10A

8 cell / 8,7A

9 cell / 7,7A

10 cell / 7A

11 cell / 6,5A

12 cell / 6A

13 cell / 5,2A

14 cell / 5A

04.02.22

MASCOT type 3540 Li-Ion Charger:		3 cell	4 cell	6 cell
Input voltage: / Line frequency:		198 - 264VAC / 50Hz		
Max output power:		252W	294W	252W
Charge control:	Charge indication:			
Step 0 < 10min	Yellow	CC 1.0A ± 0.4A, when batt voltage <9V	CC 1.0A ± 0.2A, when batt voltage <12V	CC 0.8A ± 0.4A, when batt voltage <18V
Step 0 > 10min	Red (4 blinks)	0A / 0V		
Step 1 (Constant Current)	Yellow	CC 20A +0.2/-0.3A, when 9V < Vbat < 12.6V.	CC 17.5A +0.2/-0.3A, when 12V < Vbat < 16.8V	CC 10A +0.2/-0.3A, when 18V < Vbat < 25.2V ±0.2V
Step 2 (Constant Voltage)	Flashing Yellow	CV 12.6V <14A until I charge < 1.0A or max. 2h.	CV 16.8V <12.4A until I charge < 1.0A or max. 2h	CV 25.2V < 8.8A, until I charge < 0.8A or max. 1h
Charge timer (step2, CV)		2h	2h	1h
Safety timer (all steps)	Red (5 blinks)	72h		
Step 3 (Charge Completed)	Green	0A		
Restart voltage		12.3V	16.4V	24.6V
Formation Charge (Step 0)		Low current start-up of deeply discharged battery.		
Wake-up of deeply discharged battery.		Yes, will apply voltage which deactivates deep discharge protection in battery pack.		
Indication when "Battery not connected"		Flashing Green (1s/1s)		
Leakage current from battery with mains switched off:		< 150µA @ 12.6V	< 170µA @ 16.8V	< 140 µA @ 25.2V
Efficiency (at 100% load, 115V) approx.:		>91%		>92%
Switch frequency approx.:		65kHz		
Ripple:		< 100mVp-p		
NTC input, on request (std. is 10kohm, B-value approx. (4000K)		0 - 45 °C: Normal charge. Battery temp. < 0 °C (too cold) or > 45°C (too hot): No charge, wait until temp. is OK. WAIT MODE INDICATIONS: Yellow with 1 red blink: Battery temperature is too low (<0°C) Yellow with 2 red blinks: Battery temperature is too high (>45°C)		
Protection:		Thermal protection. Prevents sparking. Short circuit proof. Error Indication: Red (3 blinks) Safety timer: 72h. Error Indication: Red (5 blinks) Protected against reversed polarity. Error Indication: Red (2 blinks) Safety timer. Error Indication: Red (5 blinks) No charge (or charge terminated) if connecting wrong battery pack with higher voltage. Indication: LED is OFF.		
Charging of wrong, lower voltage battery pack limited to (A) and will be terminated after 10 min. Indication: Red (4 blinks)		1.0A	1.0A	0.8A
Temperature range:		Operating: +25 to +40°C. Storage: +25 to +65°C		
Derating: Charge current automat. reduced to approx.:		14A at 40°C	14A at 40°C	7.5A at 40°C
Safety:		EN 60601-1		
Insulation class:		Double insulated (Class II)		
Insulation voltage: Primary - secondary:		4000VAC / 5700VDC		
EMC standards:		EN 60601-1-2: 2015 (Edition 4)		
Input terminal:		2 pin IEC60320 or mains cable		
Output terminals:		Cord with open ends or XLR plug		
Protection against ingress (IP-code):		IP44		
Recommended battery capacity:		20 - 800Ah	14A at 40°C	10 - 400Ah
Dimensions:		210 × 113 × 53 mm		
Weight approx.:		With mains cable 1400g. With IEC60320 1150g		

Technical drawing

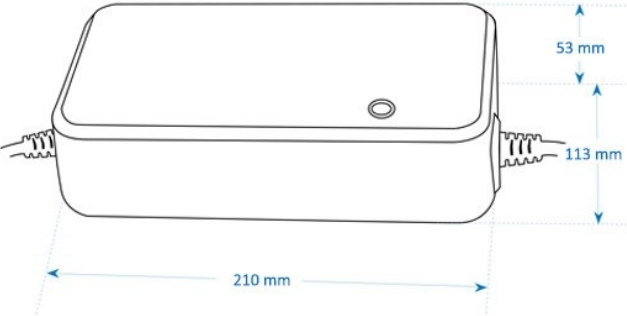

Charging characteristics and LED indication *

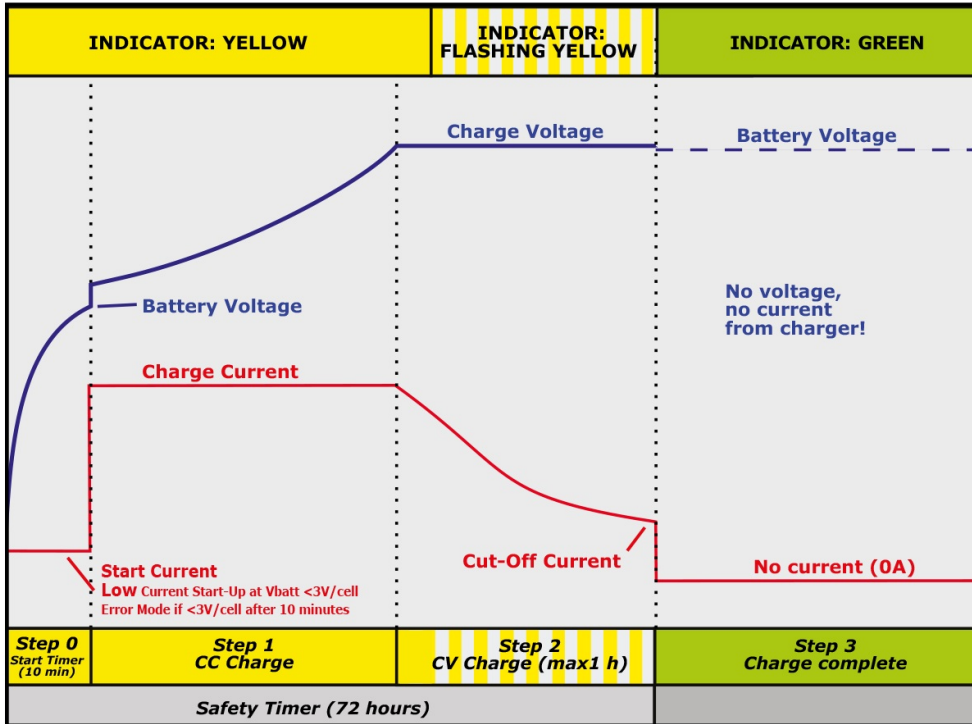

* an animated video of this charging progress is available on our website

BATTERY NOT CONNECTED INDICATIONS

Battery not connected is indicated by FLASHING GREEN. In this mode charger will apply short pulses attempting to wake up deeply discharged batteries.

ERROR INDICATIONS

- 2 red blinks: Battery is connected to charger with wrong polarity!
- 3 red blinks: Charger output is shorted. Check output cable connection!
- 4 red blinks: Battery voltage is low. Check battery status or voltage.
- 5 red blinks: Safety timer has run out. Check battery status or capacity.
- LED off: Battery voltage is too high. Check battery voltage.

WAIT MODE INDICATIONS

- Yellow with 1 red blink: Battery temperature is too low ($< 0^{\circ}C$)
- Yellow with 2 red blink: Battery temperature is too high ($> 45^{\circ}C$)

EU & UK Declaration of Conformity



We, the responsible manufacturer;

Company Name: **Mascot Electronics AS**
 Postal Address: **P.O.Box 177, N-1601 Fredrikstad, NORWAY**
 Visiting Address: **Mosseveien 109, N-1624 Gressvik, NORWAY**
 Telephone: **(+47) 69 36 43 00** E-mail: **sales@mascot.com** WEB: **www.mascot.com**

declare that this Declaration is issued under our sole responsibility and belongs to the following product(s):

Product and intended purpose: **Battery Charger for Li-Ion-, LiFePO₄-, Li-Titanate, Lead-Acid or NiMH/NiCd Batteries**

Brand(s): ** and/or **MASCOT** (may also carry additional customer name, logo or trade mark)**

Type(s)/Model(s)/ UDI-DI: **3540**
 (may also carry additional customer model name or part number)

Batch / Serial No./ UDI-PI: **all CE- and/or UKCA- marked products produced from the date indicated below**
 (for production date: see marking on the product)

Description: **Input: max. 2.4 A, 220 - 240 VAC, 50 Hz or max. 4.3 A, 110 - 120 VAC, 60 Hz**

Output for Lead-Acid Batteries:

6 V: 7.35 V ±10%, max. 20 A, max. 150 W	24 V: 29.4 V ±10%, max. 10 A, max. 294 W
12 V: 14.7 V ±10 %, max. 20 A, max. 294 W	36 V: 44.1 V ±10%, max. 6.6 A, max. 294 W
18 V: 22.2 V ±10%, max. 13.2 A, max. 294 W	48 V: 58.8 V ±10%, max. 5.0 A, max. 294 W

Output for Li-Ion Batteries:

1 cell: 4.2 V ±10%, max. 20 A, max. 84 W	8 cell: 33.6 V ±10%, max. 8.7 A, max. 294 W
2 cell: 8.4 V ±10%, max. 20 A, max. 168 W	9 cell: 37.8 V ±10%, max. 7.7 A, max. 294 W
3 cell: 12.6 V ±10%, max. 20.0A, max. 294 W	10 cell: 42.0 V ±10%, max. 7.0 A, max. 294 W
4 cell: 16.8 V ±10%, max. 17.5 A, max. 294 W	11 cell: 46.2 V ±10%, max. 6.3 A, max. 294 W
5 cell: 21.0 V ±10%, max. 14 A, max. 294 W	12 cell: 50.4 V ±10%, max. 5.8 A, max. 294 W
6 cell: 25.2 V ±10%, max. 11.6 A, max. 294 W	13 cell: 54.6 V ±10%, max. 5.3 A, max. 294 W
7 cell: 29.4 V ±10%, max. 10 A, max. 294 W	14 cell: 58.8 V ±10%, max. 5.0 A, max. 294 W

Output for LiFePO₄ Batteries:

1 cell: 3.65 V ±10%, max. 20 A, max. 75 W	9 cell: 32.85 V ±10%, max. 9.0 A, max. 295 W
2 cell: 7.30 V ±10%, max. 20 A, max. 150 W	10 cell: 36.5 V ±10%, max. 8.0 A, max. 294 W
3 cell: 10.95 V ±10%, max. 20 A, max. 220 W	11 cell: 40.15 V ±10%, max. 7.3 A, max. 294 W
4 cell: 14.60 V ±10%, max. 20 A, max. 294 W	12 cell: 43.8 V ±10%, max. 6.7 A, max. 294 W
5 cell: 18.25 V ±10%, max. 16 A, max. 294 W	13 cell: 47.45 V ±10%, max. 6.1 A, max. 294 W
6 cell: 21.9 V ±10%, max. 13.4 A, max. 294 W	14 cell: 51.1 V ±10%, max. 5.5 A, max. 281 W
7 cell: 25.55 V ±10%, max. 11.5 A, max. 294 W	15 cell: 54.75 V ±10%, max. 5.2 A, max. 284 W
8 cell: 29.20 V ±10%, max. 10 A, max. 294 W	16 cell: 58.4 V ±10%, max. 5.0 A, max. 294 W

Output for Lithium Titanate Batteries:

1 cell: 2.85 V ±10%, max. 20 A, max. 60 W	11 cell: 31.35 V ±10%, max. 9.3 A, max. 294 W
2 cell: 5.7 V ±10%, max. 20 A, max. 115 W	12 cell: 34.2 V ±10%, max. 8.5 A, max. 294 W
3 cell: 8.55 V ±10%, max. 20 A, max. 171 W	13 cell: 37.05 V ±10%, max. 7.9 A, max. 294 W
4 cell: 11.4 V ±10%, max. 20 A, max. 230 W	14 cell: 39.9 V ±10%, max. 7.3 A, max. 294 W
5 cell: 14.25 V ±10%, max. 20 A, max. 285 W	15 cell: 42.75 V ±10%, max. 6.8 A, max. 294 W
6 cell: 17.1 V ±10%, max. 17 A, max. 294 W	16 cell: 45.6 V ±10%, max. 6.4 A, max. 292 W
7 cell: 19.95 V ±10%, max. 14.7 A, max. 294 W	17 cell: 48.45 V ±10%, max. 5.5 A, max. 268 W
8 cell: 22.8 V ±10%, max. 12.8 A, max. 294 W	18 cell: 51.3 V ±10%, max. 5.5 A, max. 282 W
9 cell: 25.65 V ±10%, max. 11.4 A, max. 294 W	19 cell: 54.15 V ±10%, max. 5.2 A, max. 282 W
10 cell: 28.5 V ±10%, max. 10.3 A, max. 294 W	20 cell: 57.0 V ±10%, max. 5.0 A, max. 285 W

Output for NiMH/NiCd Batteries:

2 cell: max. 20 A, max. 3.60 V ±10%, max. 294 W
3-6 cell: max. 20 A, max. 10.8 V ±10%, max. 294 W
4-8 cell: max. 20 A, max. 14.4 V ±10%, max. 294 W
5-10 cell: max. 16.3 A, max. 18.0 V ±10%, max. 294 W
6-12 cell: max. 13.6 A, max. 21.6 V ±10%, max. 294 W
10-20 cell: max. 8.1 A, max. 36.0 V ±10%, max. 294 W
10-22 cell: max. 7.4 A, max. 39.6 V ±10%, max. 294 W

NOTE: "±10%" do not indicate the tolerance of the output voltage. "±10%" indicate that the product version is certified having an output voltage within this range.

The product(s) described above are in conformity with the relevant European Union harmonisation legislation for CE-marking:

2014/35/EU	EU Directive - Safety of electrical equipment ("Low-Voltage Directive") (LVD) recast, repealing Directives 2006/95/EC & 73/23/EEC
2014/30/EU	EU Directive - Electromagnetic Compatibility (EMC) recast, repealing Directives 2004/108/EC & 89/336/EEC
93/42/EEC	EU Directive - General Medical Devices (MDD), Risk Class I Device will from 26.05.2021 be repealed by "MDR" Regulation (EU) 2017/745
2009/125/EC	EU Directive - Energy Related Products, Ecodesign (ERP) recast, repealing Directive 2005/32/EC (EUP)
2015/863/EU	EU Directive - Restriction on use of Hazardous Substances in EEE ("RoHS3") recast, repealing Directives 2002/95/EC, 2008/35/EC & 2011/65/EU

The product(s) described above are in conformity with the relevant U.K. legislation for UKCA-marking:

Electrical Equipment (Safety) Regulations 2016

Electromagnetic Compatibility (EMC) Regulations 2016

The Medical Devices (Amendment etc.) (EU Exit) Regulations 2020, Risk Class I Device

Ecodesign for Energy-Related Products (External Power Supplies) Regulations 2020

Draft Regulation, awaiting implementation

The Restriction of the Use of Certain Hazardous Substances in Electrical and Electronic Equipment Regulations 2012

The following harmonised standards and technical specifications have been applied:

(International editions and comments indicated in brackets):

Electrical Safety (to MDR/MDD-Directives):

EN 60601-1	EN 60601-1:2006 + /AC:2010 +/A1:2013 (IEC 60601-1:2005 + /A1:2012)	Medical electrical equipment, Edition 3.1
EN 60601-1-11	EN 60601-1-11:2010 Medical electrical equipment and systems used in the home healthcare environment, Edition 1.0 (IEC 60601-1-11:2010 +/COR1:2011, Ed.1.0) (also IEC 60601-1-11:2015 +/A1:2020, Ed.2.1, but not yet an EN-norm) NOTE: for products rated IPx1 or higher to standard EN 60529 only	

Electromagnetic Compatibility (to MDR/MDD-Directives):

EN 60601-1-2	EN 60601-1-2:2015 (IEC 60601-1-2:2014, Edition 4.0)	Medical equipment, EMC - Requirements and tests, Edition 4.0
--------------	--	--

Electromagnetic Compatibility (to EMC-Directive):

EN 61000-6-1	EN 61000-6-1:2007 (IEC 61000-6-1:2005, Edition 2.0) (also IEC 61000-6-1:2016, Edition 3.0, not yet an EN-norm)	Immunity-residential, comm. & light-industrial environment, Edition 2.0
EN 61000-6-3	EN 61000-6-3:2007 + /A1:2011 & /AC:2012 (IEC 61000-6-3:2007 + /A1:2010)	Emission-residential, comm. & light-industrial environment, Edition 2.1

Ecodesign to EU ERP-Directive:

Commission Regulation (EC) No 2019/1782	implementing Directive 2005/32/EC with regard to eco-design requirements for no-load condition electric power consumption and average active efficiency of external power supplies (Repealing Commission Regulation (EC) No 2019/1782 from 2020-04-01) (Note: not applicable to Battery Chargers, ref. Article 1.2 item c))
---	--

Ecodesign for U.K.:

Draft Regulation only (awaiting implementation)	Draft "Ecodesign for Energy-Related Products (External Power Supplies) Regulations 2020" (Note: not applicable to Battery Chargers)
---	---

Ecodesign for U.S.A. (Note: depends on battery used !):

US Code of Federal Regulations (CFR) Also called "DoE compliance"	10 CFR Part 430 - Energy Conservation Program for Consumer Products, 10 CFR Part 430, Subpart B - Test Procedures, 10 CFR Appendix Y to Subpart B of Part 430, Uniform Test Method for Measuring the Energy Consumption of Battery Chargers or 10 CFR Appendix Z to Subpart B of Part 430, Uniform Test Method for Measuring the Energy Consumption of External Power Supplies, whichever applicable.
California Code of Regulations (CCR) Also called "CEC-400 compliance" referring to CEC-400-2017-002 "2016 Appliance Efficiency Regulations" issued by California Energy Commission	CCR Title 20 - Public Utilities and Energy, Division 2 - State Energy Resources Conservation and Development Commission, Chapter 4 - Energy Conservation, Article 4 - Appliance Efficiency Regulations, Sections 1601 to 1609

EU & UK Declaration of Conformity



Restriction of the Use of certain Hazardous Substances (RoHS) for EU:

2015/863/EU "RoHS3"

EU Directive - Restriction on use of Hazardous Substances in EEE Restriction of the Use of certain Hazardous Substances in Electrical and Electronic Equipment

Restriction of the Use of certain Hazardous Substances for UK:

The Restriction of the Use of Certain Hazardous Substances in Electrical and Electronic Equipment Regulations 2012

Additional Information:

Compliance with harmonised standards and technical specifications may have been verified by the manufacturer, by third party testing or by a Certification Body (NCB).

The products are considered Risk Class I devices according to EU Medical Devices Directive, EU Medical Devices Regulation and the U.K. Medical Devices (Amendment etc.) (EU Exit) Regulations 2020.

The product(s) may be produced at production sites (for specific product: see "Made in"-marking on the product):

- Mascot Baltic OÜ, Taevakivi 15, EE-13619 Tallinn, ESTONIA
- Mascot Power Supplies (Ningbo) Co.,Ltd, No.128 Jinchuan Road, Zhenhai, Ningbo 315221, CHINA

The production sites are certified to standard EN 29001:2015 (ISO 9001:2015) by:

- Mascot Baltic OÜ: Metrosert, certificate ref. K-144
- Mascot Power Supplies (Ningbo) Co.,Ltd: DNV-GL, certificate ref. 179027-2015

The most recent issue of this Declaration is available at www.mascot.com.

Fredrikstad, Norway

Place of issue

2021-03-02

Date of issue

Signed on behalf of Mascot Electronics AS

Finn-Erik Wailin, Compliance Manager

Name, function, signature